

BUEIRO DUPLO TUBULAR DE CONCRETO - BOCAS NORMAIS E ESCONSAS

PLANTA NORMAL

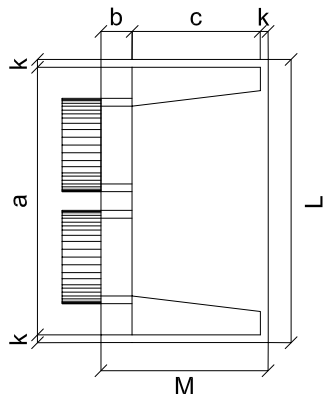

VISTA LATERAL

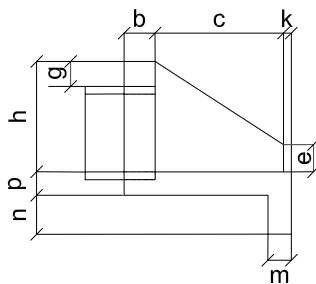

VISTA FRONTAL

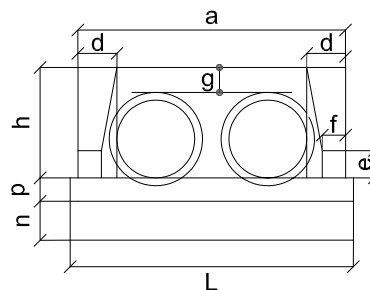

PLANTA ESCONSO

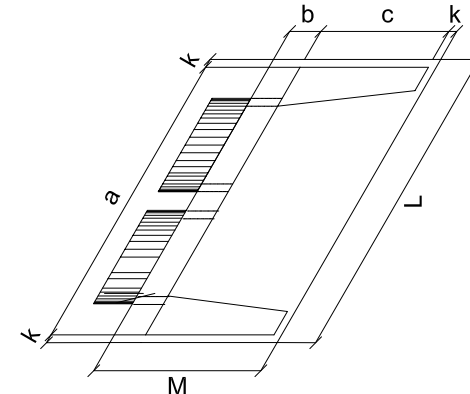

DIMENSÕES E CONSUMOS MÉDIOS PARA UMA UNIDADE

Esc.	BUEIRO DUPLO TUBULAR $\Phi = 80$															formas m ²	con creto m ³	cimento saco 50kg	areia m ³	brita 1 brita 2 m ³	água m ³	madeira m ³
	a	b	c	d	e	f	g	h	k	m	n	p	L	M								
0°	240			30									260	180	8,25	1,957	9,588	1,331	1,448	0,313	0,206	
5°	241			30									261	180	8,27	1,958	9,592	1,331	1,449	0,313	0,207	
10°	244			30									264	180	8,34	1,961	9,607	1,333	1,451	0,314	0,209	
15°	248	25	145	31									269	180	8,46	1,965	9,630	1,336	1,454	0,314	0,212	
20°	255			32	35	15	30	120	10	20	30	20	277	180	8,65	1,972	9,663	1,341	1,459	0,316	0,216	
25°	265			33									287	180	8,90	1,981	9,704	1,347	1,466	0,317	0,222	
30°	277			35									300	180	9,24	1,991	9,755	1,354	1,473	0,319	0,231	
35°	293			37									317	180	9,71	2,003	9,813	1,362	1,482	0,320	0,243	
40°	313			39									339	180	10,34	2,016	9,879	1,371	1,492	0,323	0,259	
45°	339			42									368	180	11,22	2,031	9,953	1,381	1,503	0,325	0,281	

Esc.	BUEIRO DUPLO TUBULAR $\Phi = 120$															formas m ²	con creto m ³	cimento saco 50kg	areia m ³	brita 1 brita 2 m ³	água m ³	madeira m ³
	a	b	c	d	e	f	g	h	k	m	n	p	L	M								
0°	340			40									360	230	14,92	4,408	21,600	2,998	3,262	0,705	0,373	
5°	341			40									361	230	14,96	4,412	21,617	3,000	3,265	0,706	0,374	
10°	345			41									366	230	15,09	4,422	21,668	3,007	3,272	0,708	0,377	
15°	352	40	180	41									373	230	15,31	4,439	21,753	3,019	3,285	0,710	0,383	
20°	362			43	60	25	30	163	10	23	33	23	383	230	15,64	4,463	21,870	3,035	3,303	0,714	0,391	
25°	375			44									397	230	16,10	4,494	22,019	3,056	3,325	0,719	0,403	
30°	393			46									416	230	16,74	4,531	22,200	3,081	3,353	0,725	0,418	
35°	415			49									439	230	17,59	4,573	22,410	3,110	3,384	0,732	0,440	
40°	444			52									470	230	18,76	4,622	22,647	3,143	3,420	0,740	0,469	
45°	481			57									509	230	20,39	4,676	22,911	3,180	3,460	0,748	0,510	

Esc.	BUEIRO DUPLO TUBULAR $\Phi = 100$															formas m ²	con creto m ³	cimento saco 50kg	areia m ³	brita 1 brita 2 m ³	água m ³	madeira m ³
	a	b	c	d	e	f	g	h	k	m	n	p	L	M								
0°	290			35									310	205	11,51	3,037	14,883	2,065	2,248	0,486	0,288	
5°	291			35									311	205	11,54	3,039	14,892	2,067	2,249	0,486	0,289	
10°	294			36									315	205	11,64	3,044	14,917	2,070	2,253	0,487	0,291	
15°	300	30	165	36									321	205	11,81	3,053	14,960	2,076	2,259	0,488	0,295	
20°	309			37	50	20	30	142	10	22	32	22	330	205	12,06	3,065	15,019	2,084	2,268	0,490	0,301	
25°	320			39									342	205	12,41	3,080	15,093	2,095	2,279	0,493	0,310	
30°	335			40									358	205	12,89	3,099	15,184	2,107	2,293	0,496	0,322	
35°	354			43									378	205	13,54	3,120	15,289	2,122	2,309	0,499	0,339	
40°	379			46									405	205	14,43	3,145	15,408	2,138	2,327	0,503	0,361	
45°	410			49									348	205	15,66	3,171	15,540	2,157	2,347	0,507	0,391	

Esc.	BUEIRO DUPLO TUBULAR $\Phi = 150$															formas m ²	con creto m ³	cimento saco 50kg	areia m ³	brita 1 brita 2 m ³	água m ³	madeira m ³
	a	b	c	d	e	f	g	h	k	m	n	p	L	M								
0°	410			45									430	320	23,76	7,885	38,639	5,362	5,835	1,262	0,594	
5°	412			45									432	320	23,82	7,891	38,668	5,366	5,840	1,263	0,595	
10°	416			46									437	320	24,00	7,909	38,755	5,378	5,853	1,265	0,600	
15°	424	50	260	47									445	320	24,30	7,939	38,901	5,398	5,875	1,270	0,608	
20°	436			48	80	30	30	194	10	24	34	24	458	320	24,76	7,980	39,102	5,426	5,905	1,277	0,619	
25°	452			50									474	320	25,41	8,032	39,359	5,462	5,944	1,285	0,635	
30°	473			52									497	320	26,29	8,096	39,669	5,505	5,991	1,295	0,657	
35°	501			55									525	320	27,49	8,169	40,029	5,555	6,045	1,307	0,687	
40°	535			59									561	320	29,13	8,253	40,438	5,612	6,107	1,320	0,728	
45°	580			64									608	320	31,41	8,345	40,891	5,675	6,175	1,335	0,785	

Nota:

- 1 - Dimensões em cm
- 2 - Utilizar concreto ciclópico fck \geq 15 MPa
- 3 - Utilizar preferencialmente bocas normais para bueiros escosos, ajustando o talude de aterro as alas e/ou prolongando o corpo do bueiro.